We-Fab

We Create
We Manufacture
We Deliver

SOCIAL DISTANCING PRODUCTS

Sustainable safety solutions for Office, Leisure, Retail, Education & Working Environments

Contact: info@pacs-packaging.co.uk T: 01509 434124

Are you ready to return to work?

The Covid-19 pandemic has made us re-think, re-adjust and re-design essential protective kits for your social distancing practices. We design and supply the best solutions for office, business, retail, leisure, educational & essential working environments.

Our innovative safety kits offer an affordable, reusable and greener solution to ensuring a safe environment, using readily available materials and design options which can be configured to your requirements.

Avoiding heavy acrylic, bulky packaging, long lead times and high costs we aim to be an alternative, sustainable and reliable supplier for your safety solutions.

We achieve this by working with our network of local UK suppliers and inhouse production facilities in the heart of the UK, to provide you with a reactive and reliable service.

Our standard design options can be customised or resized to meet your specific needs.

Preview how easy our units are to install with our assembly demo -
<https://www.youtube.com/watch?v=c3622y17FI4&feature=youtu.be>

We-Fab Economy Screen

Value engineered protective screen

Unique design to minimize bending and bowing, manufactured from recyclable materials. This robust screen is easily installed and can be adapted as a free-standing unit or mounted to a surface.

Delivered flat packed with clear assembly guides.

Product Specifications

Standard Size: 595mm wide x 900mm high.

Material Specification: White rigid card (structure) PET (clear screen).

No large MOQ requirements, order from 1 unit.

Tabs included on the base of screen for option to tape to counter.

Bespoke Solutions

Add your own custom logos or artwork.

Bespoke sizes available upon request.

Standard 595mm

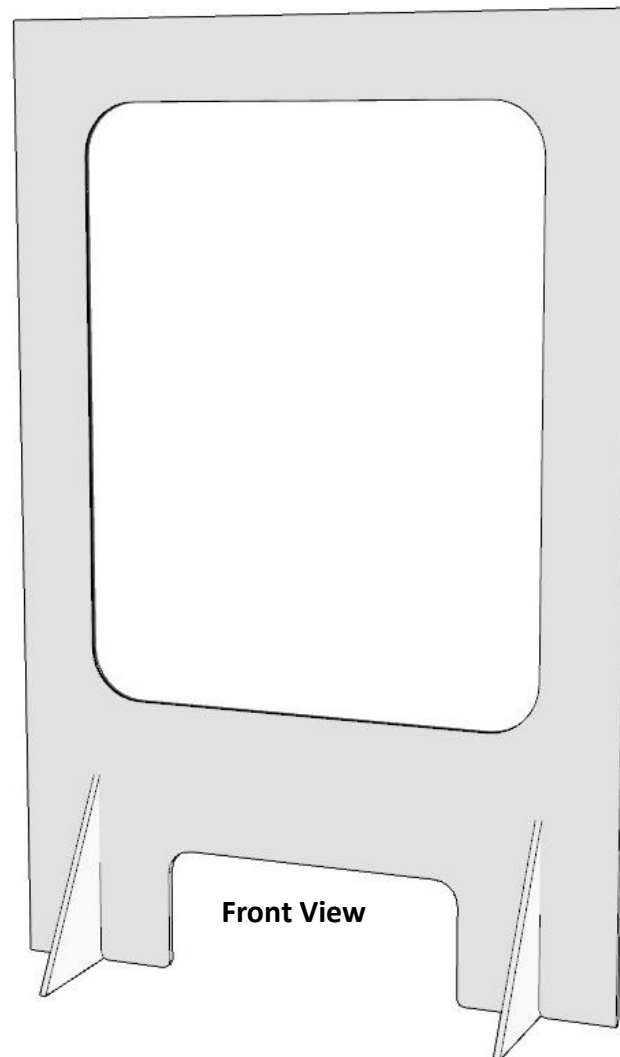

Front View

Standard 900mm

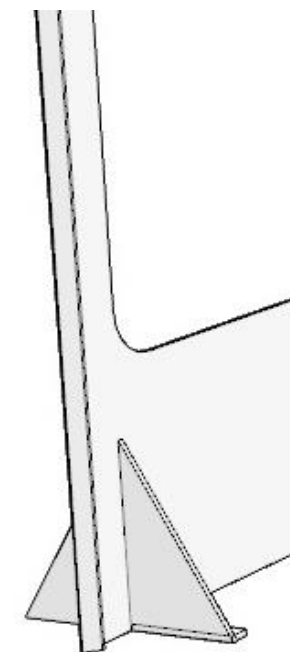

Back View

We-Fab Economy Screen

Value engineered protective screen

The We-Fab Economy Screen can be adapted to fit around your space. Using a clip system, the screens can be connected to create longer screens for larger spaces or corner brackets to close off areas and to secure more challenging areas within your environment.

Product Specifications

Option A - Fully closed off screen guard.

Option B - Access aperture at base of screens for reduced contact.

Mix & match option available with both designs.

Clip together screens offer strong and robust solution.

Can be easily disposed of or replaced if required.

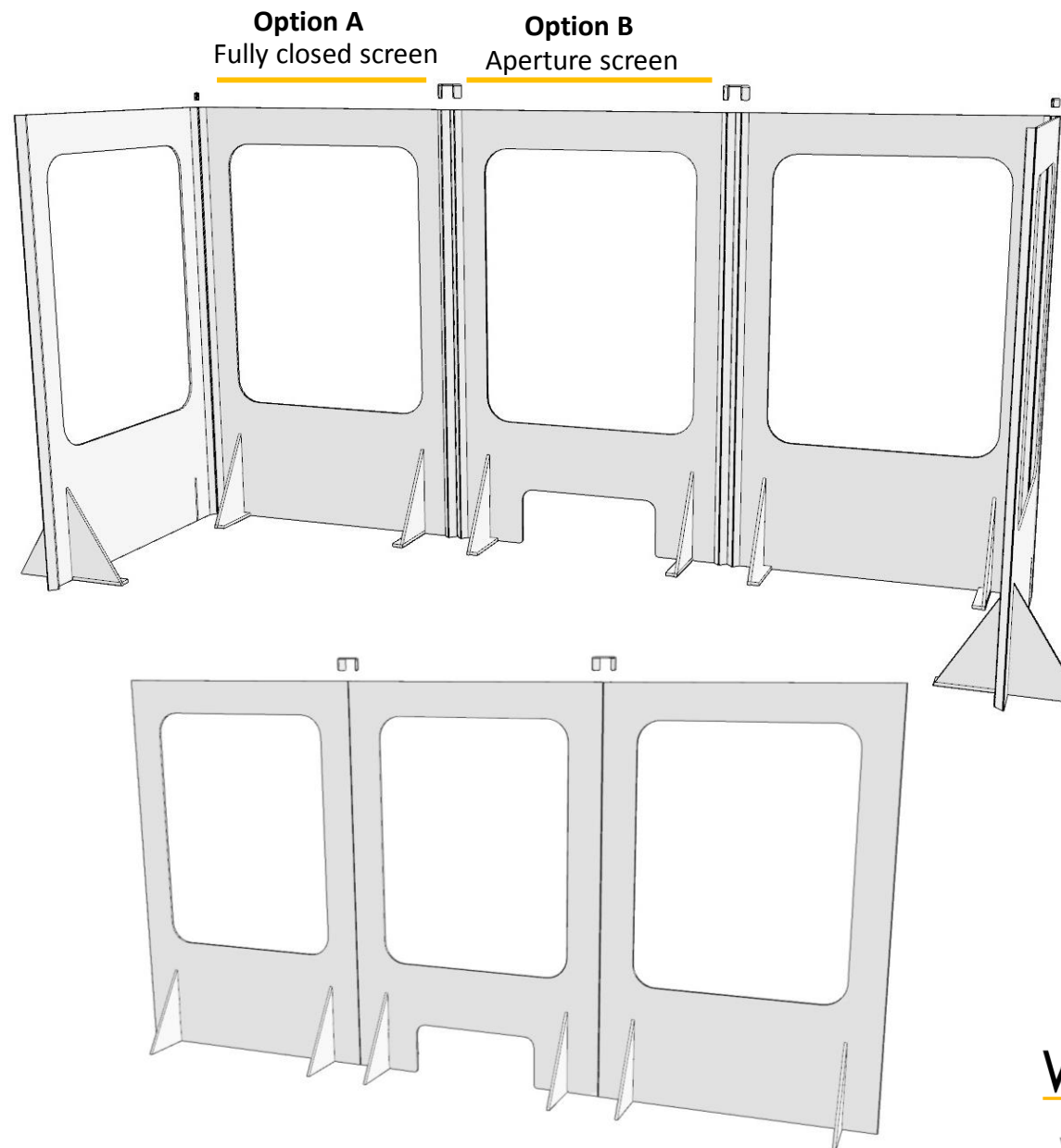

We-Fab Economy Screen

Pricing and Components

Quantity	Standard Kit Price
1 to 10	POA
11 to 50	POA
51 to 100	POA
101 to 250	POA
251 to 500	POA

Quantity	Top Vinyl Logo**	Bottom Vinyl Logo**
1 to 10	POA	POA
11 to 50	POA	POA
51 to 100	POA	POA
101 to 250	POA	POA
251 to 500	POA	POA

Quantity	Connecting clips*
1 to 10	POA
11 to 50	POA
51 to 100	POA
101 to 250	POA
251 to 500	POA

Price applies for Option A or B screen (with or without aperture).

Larger bulk prices are available on request.

Prices are Ex VAT & Delivery.

Delivery is available on request.

Above prices are "each".

* Connecting clips are sold as a set of top and bottom clip for either a straight or a corner. 1 = 2 clips.

** On quantities less than 50 the vinyl will be supplied only not applied.

Artwork is charged at £20 per design/logo or free for orders over £250.

Standard Kit

- 1 of White Screen (595mm wide x 900mm high)
- 2 of Foot inserts

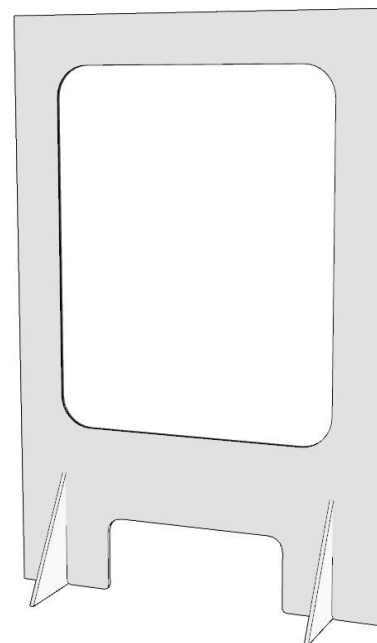

Connecting Clips

- 2 of Corner connectors for the top and bottom of the unit OR
- 2 of Straight connectors for the top and bottom of the unit

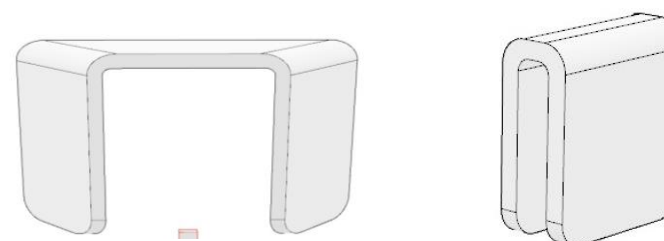

Top Vinyl Logo

- 1 of Printed vinyl (max size 65 x 250mm)

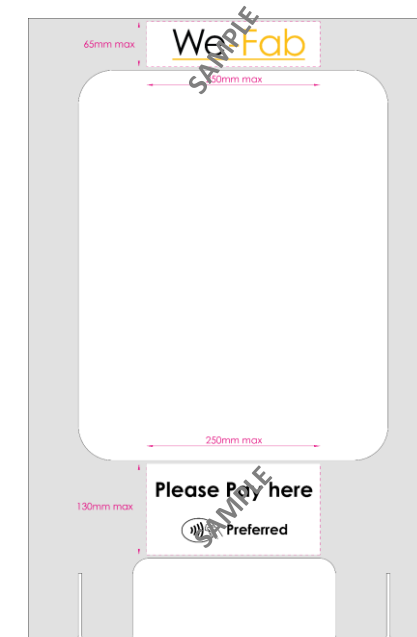

Bottom Vinyl Logo

- 1 of Printed vinyl – (max size 130 x 250mm)



We-Fab Economy Hand Sanitiser Holder

Value engineered holder

The We-Fab Economy Hand Sanitizer Holder is specifically designed for indoor or outdoor use.

A set of holes at the bottom included for rainwater drainage.

Easy installation either with supplied screws or tape.

Packaged preassembled with clear assembly guides.

Product Specifications

Standard Size: 110mm wide x 145mm high x 50mm deep.

Material Specification: 2mm HIPS either in black or white.

Supplied with screws and high adhesion VHB Tape.

No large MOQ requirements, order from 1 unit.

Bespoke Solutions

Add your own custom logos or artwork.

Bespoke sizes available to suit choice of sanitizer bottle.

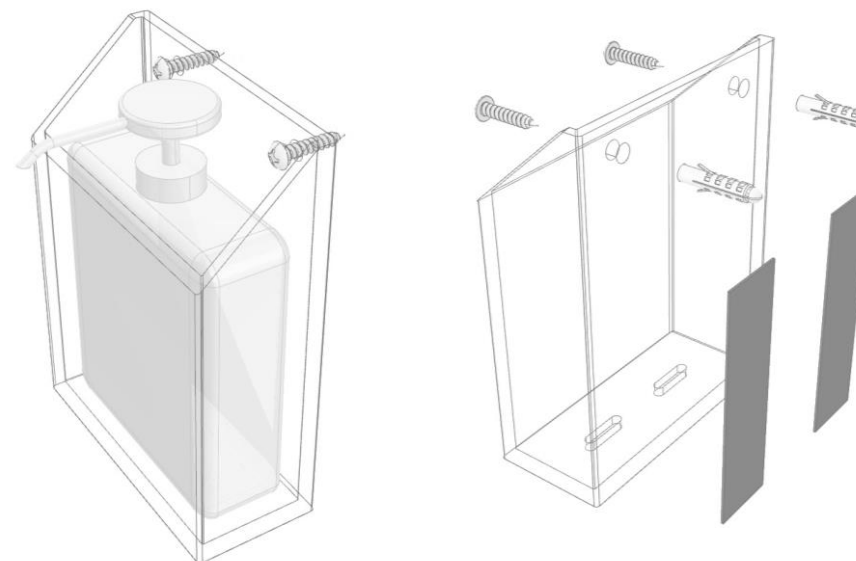
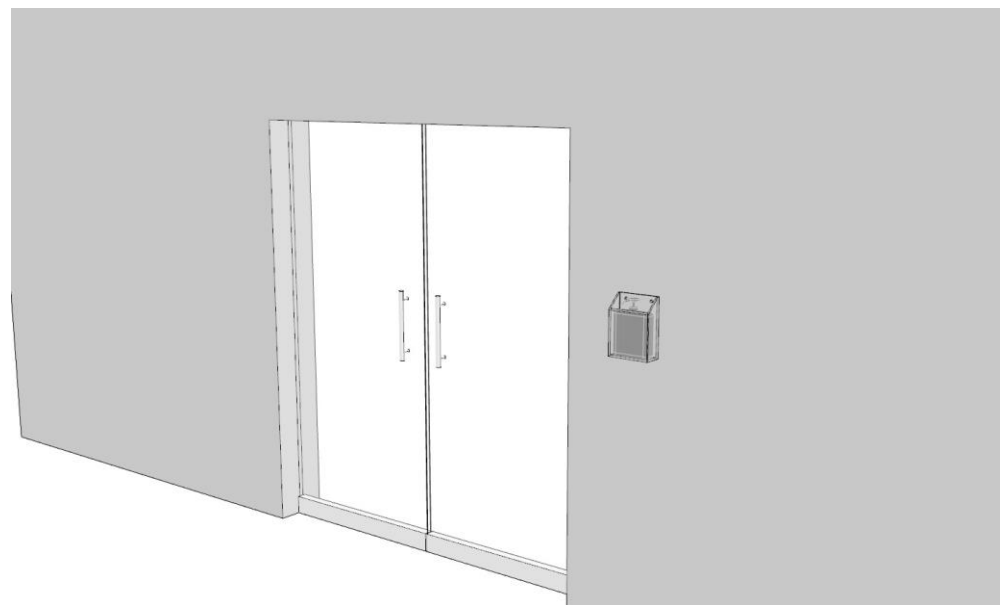

We-Fab Economy Hand Sanitiser Holder

Pricing and Components

Quantity	Holder Price
1 to 5	POA
6 to 10	POA
11 to 20	POA
21 to 50	POA
51 +	POA

Quantity	Add on Vinyl Logo*
1 to 5	POA
6 to 10	POA
11 to 20	POA
21 to 50	POA
51 +	POA

Larger bulk prices are available on request.

Prices are Ex VAT & Delivery.

Delivery is available on request.

Above prices are "each".

*Vinyl is not applied to unit, it will be sent inside the box.

Artwork is charged at £20 per design/logo or free for orders over £250.

Standard Kit

- 1 of Holder (110 x 145 x 50mm)
- 2 of VHB tapes – pre applied
- 2 of Screws
- 2 of Wall plug

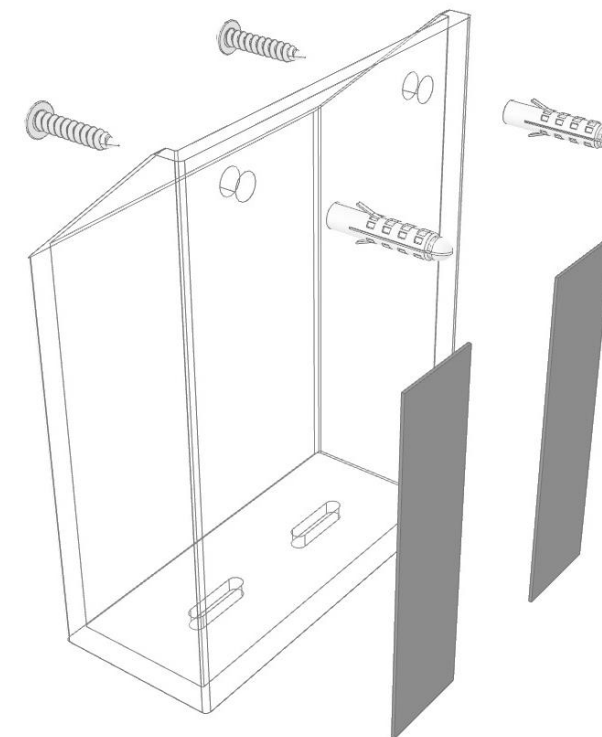

Printed vinyl logo add-on

- 1 of Printed vinyl logo (max 96 x 96mm)

We-Fab Adjustable Counter/Table Screen

The We-Fab Counter/Table Screen has been designed with an adjustable width and easy assembly on counters and surface using a clamp or foot plate.

With a smart and slim framework the optically clear screen sits taught within to create the perfect protection screen.

Delivered in a non bulky postal tube.

Product Specification

All screens are supplied with 2 upright poles.

An adjustable top brace adds stability to complete the unit.

The screens can sit flush to the counter/table or be raised slightly to allow for

minimal contact.

Easy to fix to single existing desks or to separate larger shared working areas.

Lightweight, minimal and quick installation.

Can be easily dismantled and responsibly disposed of.

Bespoke Solutions

Additional upright poles can be purchased to allow screens to go around corners.

Option A Foot Plate option

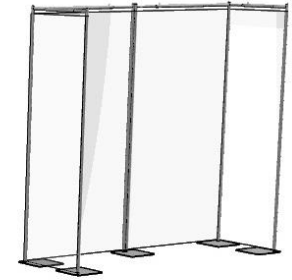
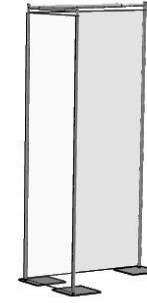
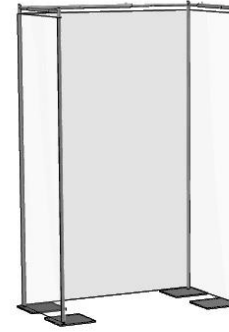
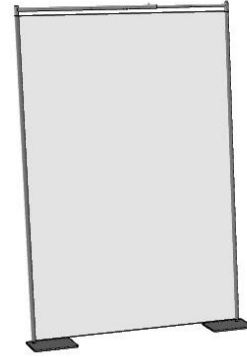

Option B Clamp option

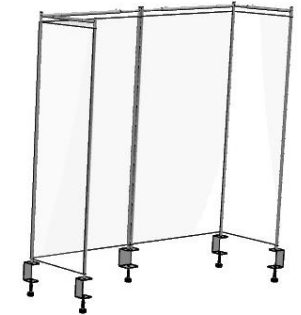
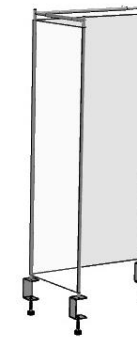
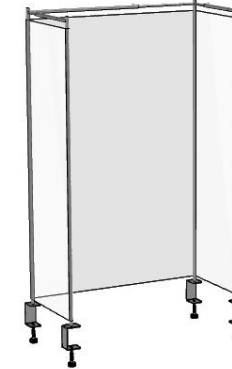
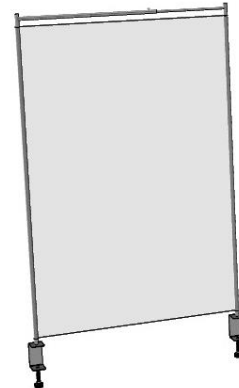

We-Fab Adjustable Counter/Table screen

Standard Height: 800mm (Pole) (Screen 750mm).

Variable Width: From 800 to 1500mm.

Option A-Supplied with foot plates.

Option B-Supplied with clamps. (Standard clamp internal capacity is 17 - 42mm).

Material Specification:

-Aluminum Frame (structure)

- Super thin grade PE (Optically clear screen).

MOQ: No large MOQ requirements, order from 1 unit.

Bespoke Solutions

Bespoke screen heights and larger widths available.

Additional sections can be added.

Large size clamps are available upon request.

Extensions are available for additional protection when sitting next to someone.

Option A
Foot Plate option

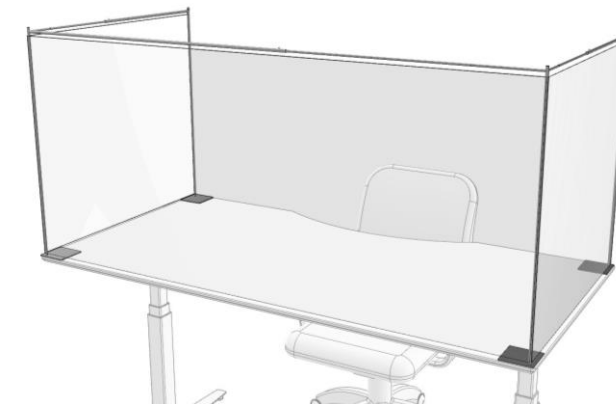

Option B
Clamp option

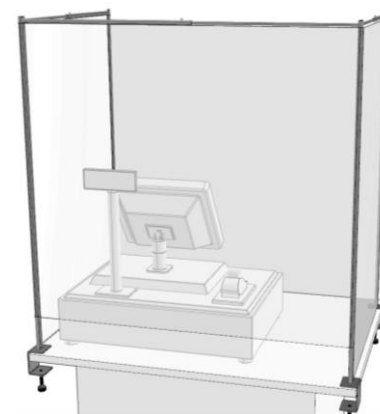
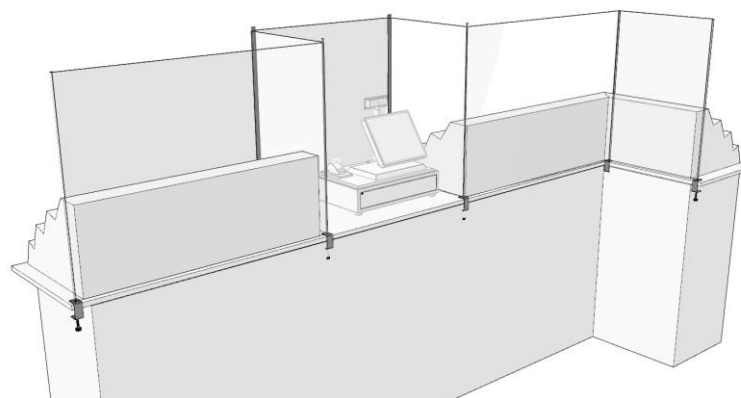

We-Fab Adjustable Counter/Table screen

Pricing and Components

Quantity	Standard Screen Price
1 to 10	POA
11 to 50	POA
51 to 100	POA
101 to 250	POA
251 to 500	POA
501 to 1000	POA
1000+	POA

Quantity	Additional Pole Price**
1 to 10	POA
11 to 50	POA
51 to 100	POA
101 to 250	POA
251 to 500	POA
501 to 1000	POA
1000+	POA

Larger bulk prices are available on request.
 Prices are Ex VAT & Delivery.
 Delivery is available on request.
 Above prices are "each".

**Additional pole is required to go around a corner, this also comes with an additional cross brace for the corner section.

Standard Screen Kit

- 2 of Upright poles with clamps or feet
- 1 of Screen attached to upright poles
- 2 of Clamp thumb screws
- 1 of Adjustable cross bar with clip attachments (800 – 1500mm)

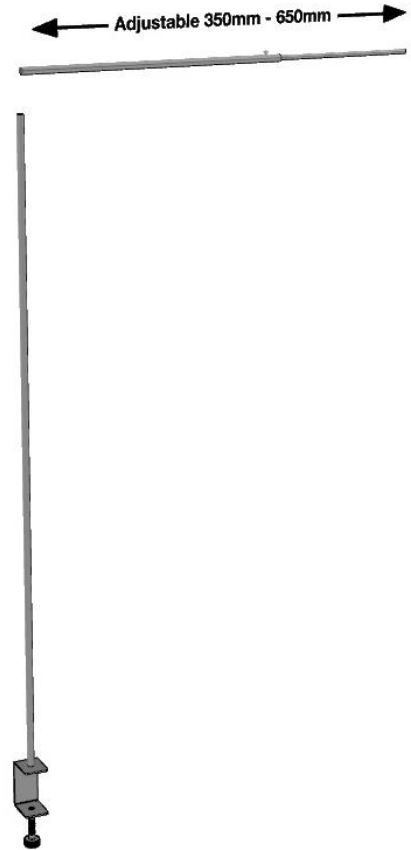
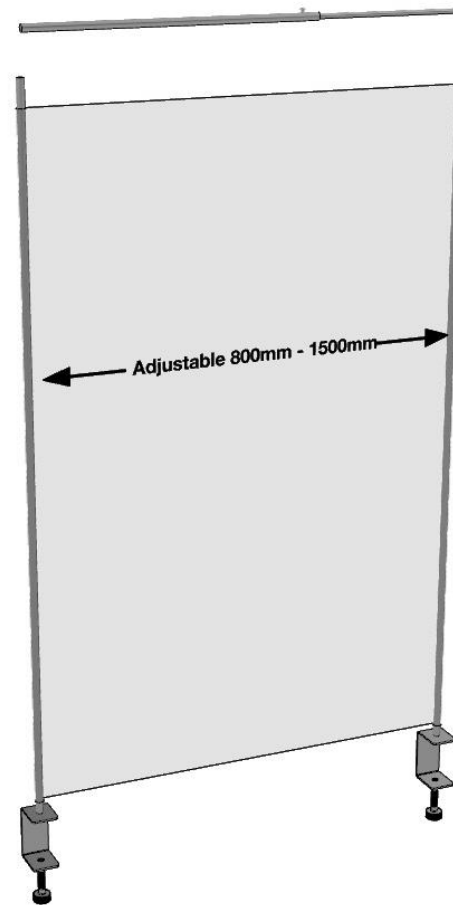

Additional Pole

- 1 of Upright Pole with clamps or feet
- 1 of Adjustable cross bar with clip attachments (350 – 650mm)

We-Fab Floor Standing Screen

The We-Fab Floor Standing Screen can be used to create the perfect safety partition within a busy and active space.

With a smart and slim framework the optically clear screen sits taught within to create the perfect protection screen.

Easily set up and suitable for all types of working environments.

Packaged in a non bulky postal tube.

Product Specification

Our free-standing Screens are supplied with 2 upright poles and 2 cross bars.

Additional cross bars can be purchased to joined screens together to make a stronger or encased partition.

We would recommend using additional cross bars when joining more than one screen.

Heavy duty tape can be provided with feet for single free standing screens for added security if required upon request.

Lightweight, quick and minimal installation.

Can be easily dismantled and responsibly disposed of.

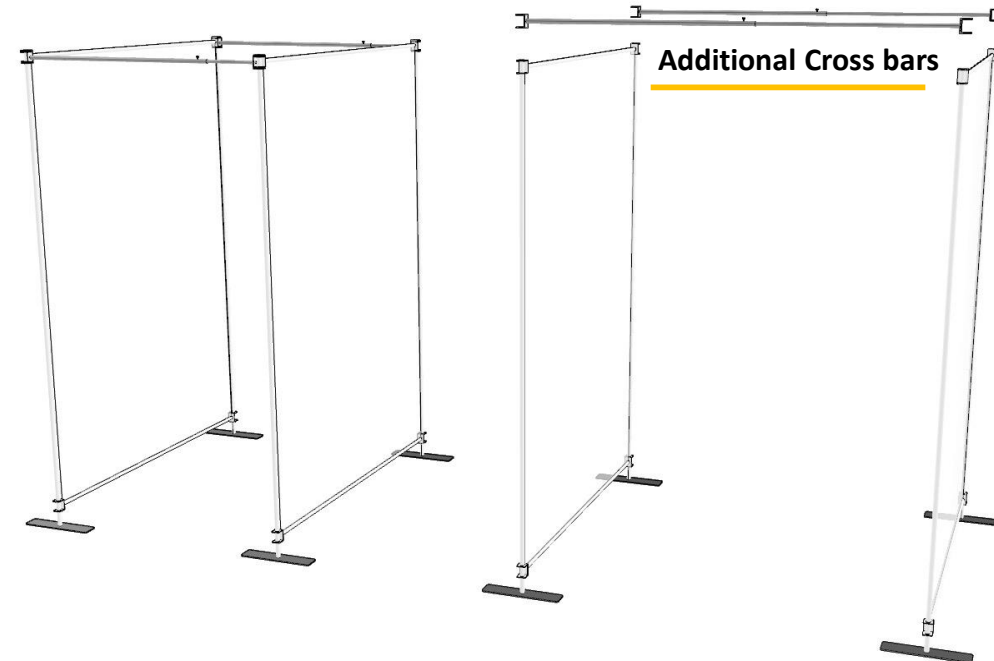
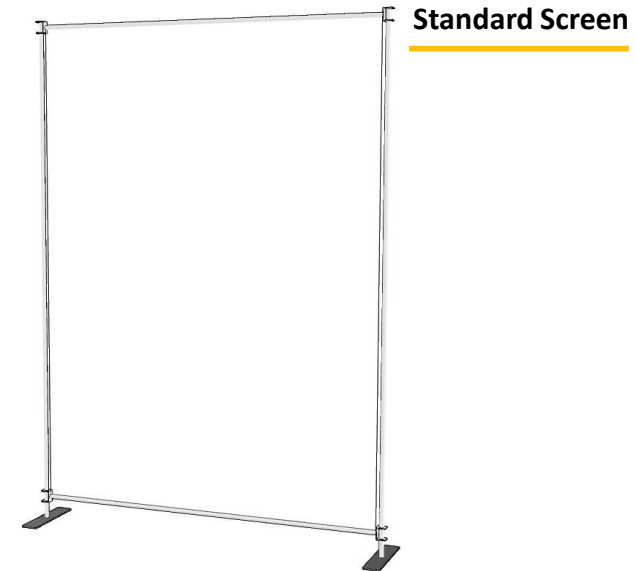

We-Fab Floor Standing Screen

Standard Height: 2200mm.

Standard Widths: 1500mm & 1100mm

Supplied with foot plates.

Material Specification:

-Aluminum Frame (structure)

- Super thin PE (Optically clear screen).

MOQ: No large MOQ requirements, order from 1 unit.

Bespoke Solutions

Bespoke screen heights and Larger widths available.

Additional sections can be added.

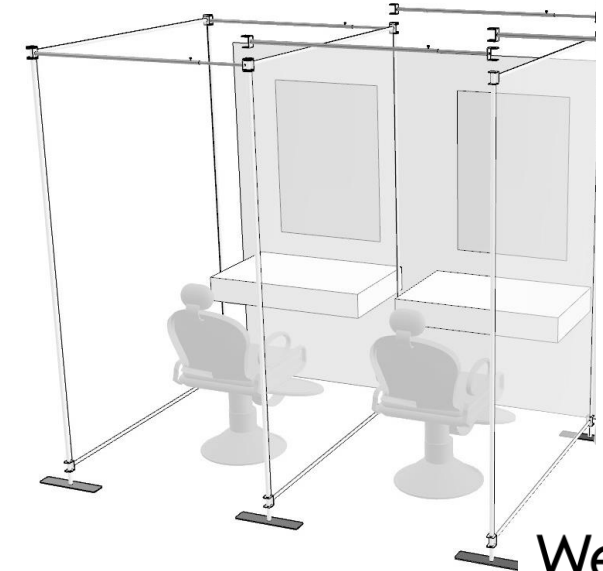
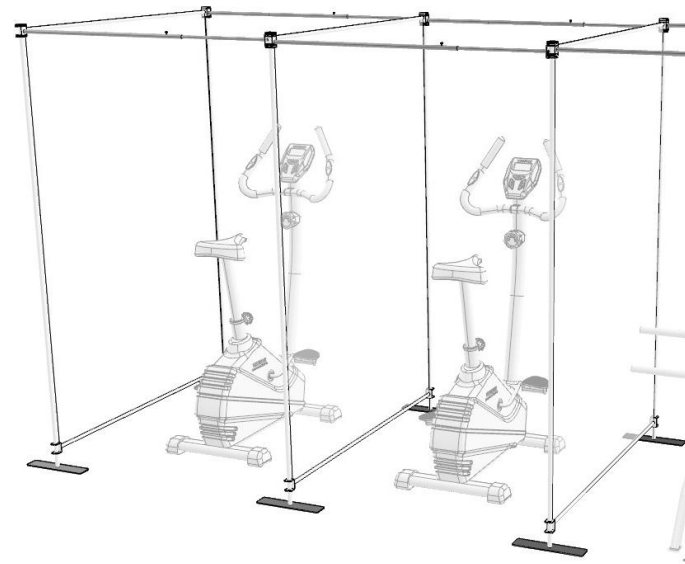
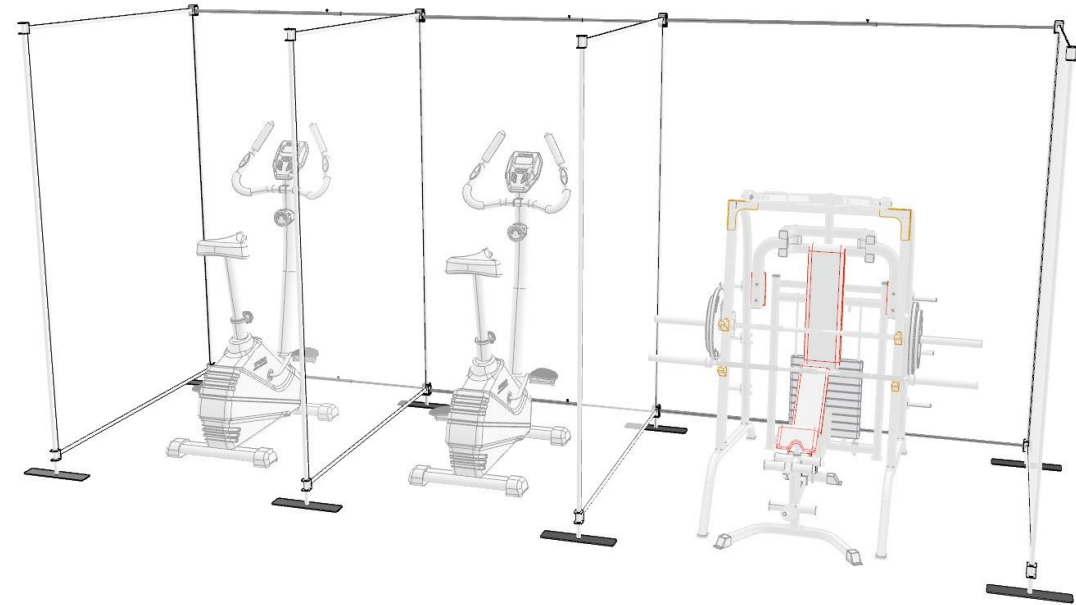

We-Fab Floor Standing Screen

Pricing and Components

Quantity	Standard Screen 1500mmW	Standard Screen 1100mmW
1 to 10	POA	POA
11 to 50	POA	POA
51 to 100	POA	POA
101 to 250	POA	POA
251 to 500	POA	POA
501 to 1000	POA	POA
1000+	POA	POA

Quantity	Additional Cross Bar Price
1 to 10	POA
11 to 50	POA
51 to 100	POA
101 to 250	POA
251 to 500	POA
501 to 1000	POA
1000+	POA

Larger bulk prices are available on request.

Prices are Ex VAT & Delivery.

Delivery is available on request.

Above prices are "each".

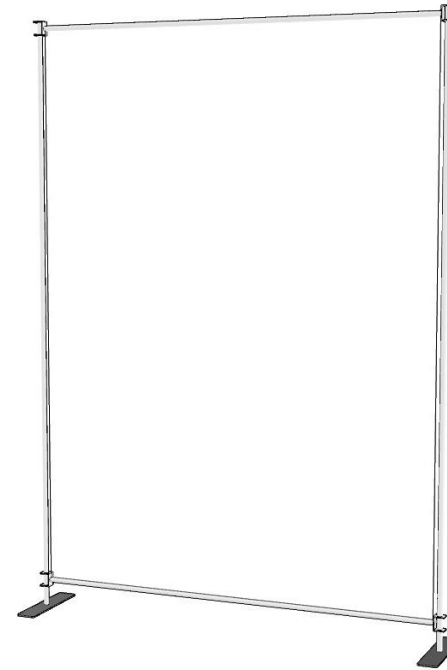

Standard Screen Kit

- 2 of Upright poles with feet
- 1 of Screen attached to cross bar poles

Additional Cross Bar

- 1 of Cross bar (1050 to 1900mm)



The fine print..

Material

Our products are always finished to the highest of standard, but due to the nature of the material there may be some vary small marks upon close inspection on any of the aluminium products. Some screen widths may vary slightly dependant on stock and time of order.

Stock

We hold a high quantity of raw material stock. However due to the high demand of screens we are unable to reserve stock. Stock will be allocated upon receipt of order.

Lead time

Lead times will vary dependant on order size, we cannot confirm exact lead times until placement of order. We hold large stocks all of the raw materials and products are made to orders.

Artwork

Artwork design time will be charged at £20 per design, on orders below £250. This service will be free of charge for orders above this amount. (1 full set of artwork per item only).

Delivery

Delivery is not included with any of our products, but can be arranged and quoted for at the time of ordering. Delivery options to mainland UK only. Collections are also available but with strict social distancing guidelines.

VAT

All prices shown are exclusive of VAT.
VAT will be added upon order.

Bespoke Items

All of our products can be customised to your requirements and we are happy to accommodate your needs. Bespoke orders will be subject to a minimum quantity order, subject to the types of change you would like.

We-Fab

We Create
We Manufacture
We Deliver

Thank You

Contact: info@pacs-packaging.co.uk T: 01509 434124

We-Fab Ltd, Unit 2k, Old Dalby Trading Estate, Station Road, Old Dalby Melton Mowbray, LE14 3NJ

VAT No. 337535685 Company No. 12320283
